

RoHS



MLVG0402 Series Engineering Specification

1. Scope

- (1) Lead free type
- (2) SMD type zinc oxide based ceramic chip
- (3) Insulator over coat keeps excellent low and stable leakage current
- (4) Plating termination provided good solder-ability characteristic
- (5) Wide operating voltage range, VDC : 5.5V to 18V
- (6) Quick response time (<1ns)
- (7) Low clamping voltage
- (8) Meet IEC 61000-4-2 standard
- (9) Low capacitance can meet high speed single transient voltage protection

Applications

Low Capacitance Product Applications for High Speed I/O port such as HDMI, DVI, USB, and IEEE1394 etc.

Normal capacitance product applications for I/O Port such as RS232, USB, PS2, VGA, Audio on Mother Board and Notebook, Set-Top Box, MP3 Players, DVD Players, and Docking System etc.

2. Explanation of Part Number

<u>MLV</u>	<u>G</u>	<u>0402</u>	<u>3R0</u>	<u>T</u>	<u>V18</u>	—	—
(1)	(2)	(3)	(4)	(5)	(6)	(7)	(8)

- (1) Series Type: MLV — Multilayer Varistor
- (2) Model Code
- (3) Chip Size (EIA): 0402
- (4) Capacitance: Value- $XR_X=0.XpF$, Ex: 3R0=3.0pF
- (5) Capacitance Tolerance: T $\pm 1.4pF$, Q $\pm 2.0pF$
- (6) Working Voltage: V_{DC}
- (7) Special Code
- (8) Special Code

3. Construction & Dimension

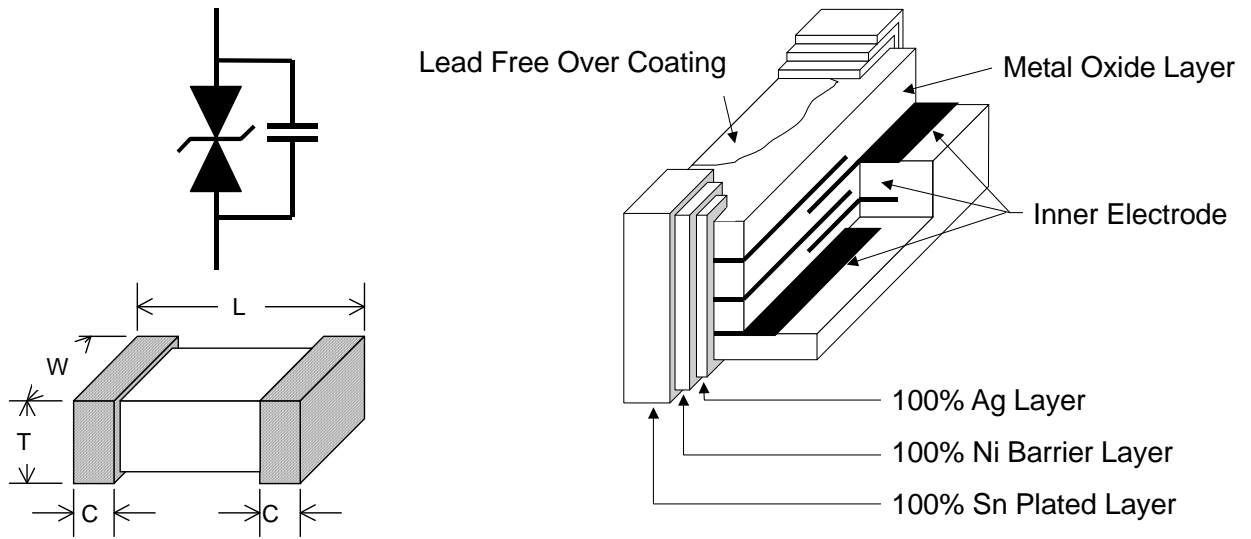

Unit: mm	0402
L	0.96±0.12
W	0.48±0.07
T	0.50±0.10
C	0.25±0.15

4. Part Characteristics

General Characteristics

Part Number	Rated Voltage	Varistor Voltage	Clamping Voltage	Capacitance
	V _{DC} (V)	V _V (V)	V _C (V)	C _P (pF)
MLVG04023R0TV18BP	~18	22~34	58	3.0
MLVG04025R0QV18BP	~18	22~34	58	5.0

** For special part number which is not shown in the above table, please contact with our sales department if you needed.

V_{DC} – Maximum DC operating voltage the varistor can maintain and not exceed 10µA leakages current

V_V –Voltage across the device measured at 1mA DC current. Equivalent to V_b, “break down voltage”.

V_C – Maximum peak voltage across the varistor measured at 8/20µs waveform and 1A pulse current

*: Maximum peak current across the varistor with 8/20µs waveform and 0.5A pulse current.

C_p – Device capacitance measured with 1 V_{rms} at 1MHz.

5. General Electrical Specifications

5.1 General Technical Data

Operating temperature	-40°C ~ +85°C
Storage temperature (on board)	-40°C ~ +85°C
Response time	<1 ns
Solderability	245±5°C, 3±1sec
Solder leach resistance	260±5°C, 10±1sec

5.2 Environmental Performance

Characteristics	Specifications	Test condition
Bias humidity	$\Delta V_V / N_V \leq \pm 10\%$	90%RH, 40°C, Working voltage, 1000 hours
Thermal shock	$\Delta V_V / N_V \leq \pm 10\%$	-40°C to 85°C, 30 min. Cycle, 5 cycles
Full load voltage	$\Delta V_V / N_V \leq \pm 10\%$	Working voltage, 85°C, 1000 hours

5.3 Storage Condition with Package

Storage Time: 12 months max.

Storage Temperature: 5°C to 40°C

Relative Humidity: 65%

6. Taping Package and Label Marking

6.1 Carrier Tape Dimensions

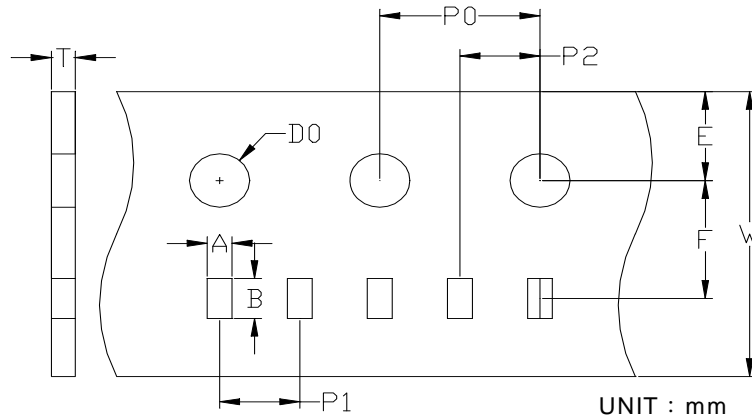

Type	A	B	W	E	F	P0	P1	P2	D0	T
0402	0.59 ± 0.03	1.12 ± 0.03	8.0 ± 0.1	1.75 ± 0.05	3.5 ± 0.05	4.0 ± 0.1	2.0 ± 0.05	2.0 ± 0.05	1.55 ± 0.05	0.60 ± 0.03

6.2 Taping Reel Dimensions

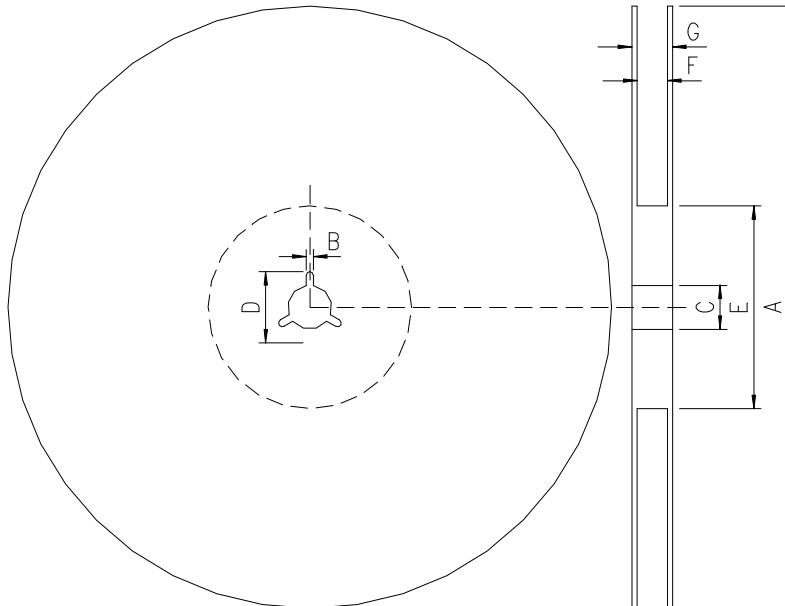

A	178.0 \pm 2.0
B	2.0 \pm 0.5
C	13.0 \pm 0.5
D	21.0 \pm 0.8
E	62.0 \pm 1.5
F	9.0 \pm 0.5
G	13.0 \pm 1.0

6.3 Taping Specifications

There shall be the portion having no product in both the head and the end of taping, and there shall be the cover tape in the head of taping.

6.4 Label Marking

The label specified as follows shall be put on the side of reel.

- (1) Part No.
- (2) Quantity
- (3) Lot No.

* Part No. And Quantity shall be marked on outer packaging.

6.5 Quantity of Products in the Taping Package

- (1) Standard quantity : 10,000pcs/Reel for MLVG 0402 series
- (2) Shipping quantity is a multiple of standard quantity.

7. Precautions for Handling

7.1 Solder Cream in Reflow Soldering

Refer to the recommendable land pattern as printing mask pattern for solder cream.

- (1) Print solder in a thickness of 150 to 200 μm .

Dimensions: millimeters (inches)

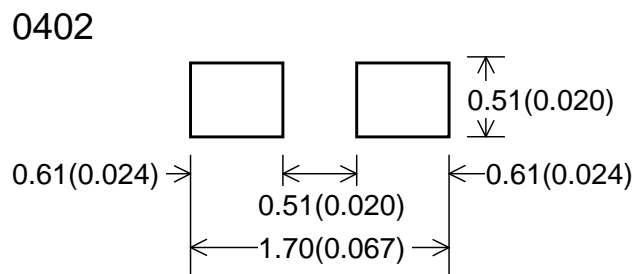

7.2 Precaution for Handling of Substrate

Do not exceed to bend the board after soldering this product extremely.

(Reference examples)

- Mounting place must be as far as possible from the position, which is close to the break line of board, or on the line of large holes of board.
- Do not bend extremely the board, in mounting another component.
If necessary, use back-up pin (support pin) to prevent from bending extremely.
- Do not break the board by hand. We recommend using the machine or the jig to break it.

7.3 Precaution for Soldering

Note that rapid heating, rapid cooling or local heating will easily damage this product. Do not give heat shock over 100°C in the process of soldering. We recommend taking preheating and gradual cooling.

7.4 Recommendable Reflow Soldering

Profile Feature	Pb-Free Assembly
Average Ramp-Up Rate (T _{smax} to T _p)	3° C/second max.
Preheat – Temperature Min (T _{smin}) – Temperature Max (T _{smax}) – Time (t _{smin} to t _{smax})	150 °C 200 °C 60-180 seconds
Time maintained above: – Temperature (T _L) – Time (t _L)	217 °C 60-150 seconds
Peak/Classification Temperature (T _p)	260 °C
Time within 5 °C of actual Peak Temperature (t _p)	20-40 seconds
Ramp-Down Rate	6 °C/second max.
Time 25 °C to Peak Temperature	8 minutes max.

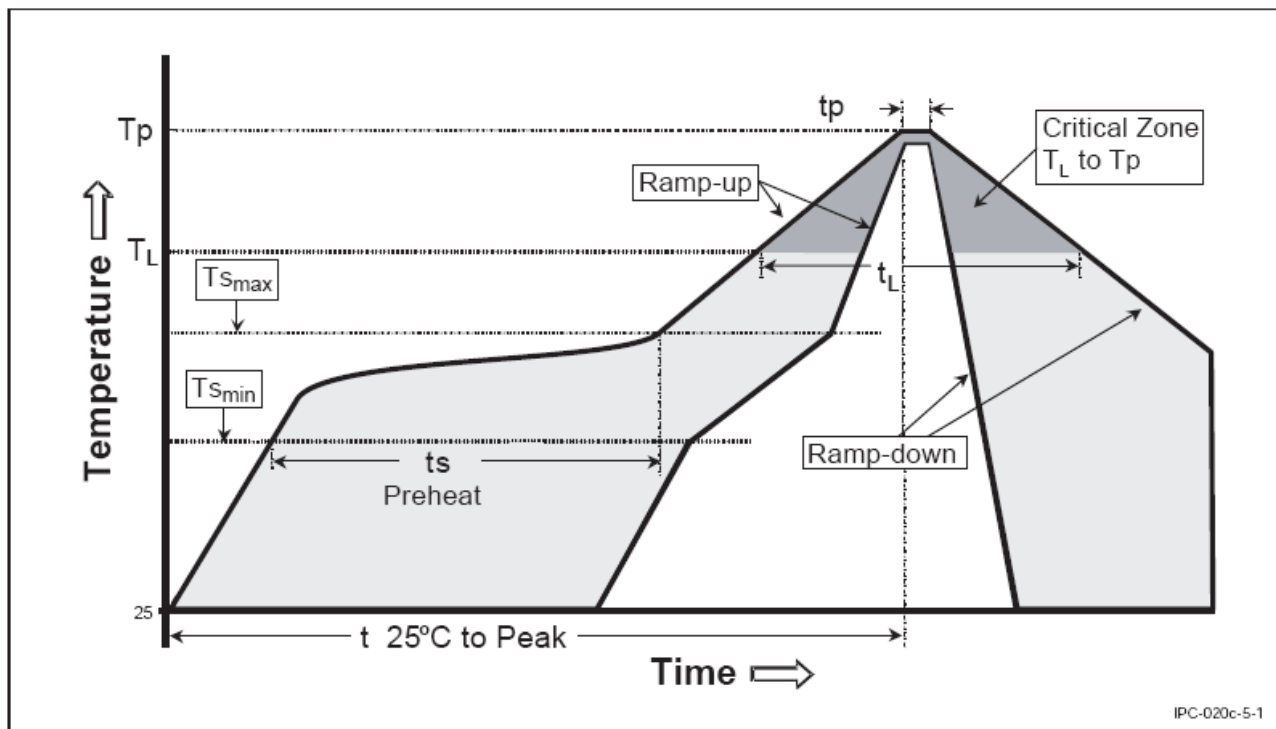

*According to J-STD-020C

7.5 Soldering Gun Procedure

Note the follows, in case of using solder gun for replacement.

- (1)The tip temperature must be less than 350°C for the period within 5 seconds by using soldering gun less than 30 W.
- (2)The soldering gun tip shall not touch this product directly.

7.6 Soldering Volume

Note that excess of soldering volume will easily get crack the body of this product.